

Handabsperrventil Serie VHK

Grosser äquivalenter Querschnitt: 2.0 bis 17.5 mm²
 Leicht zu betätigender Drehknopf: 0.43 bis 1.4 kgfcm
 Sitzventil mit gutem Dichtungseffekt
 Der min. Schlauch-Aussen- \varnothing ist $\varnothing 4$.
 Je nach Leitungssystem kann aus 4 Ausführungen ausgewählt werden.
 Der Drehknopf des 3/2-Wegeventils gibt in geschlossener Stellung den Restdruck über die Seite A ab. (Es gibt keinen Entlüftungsanschluss.)

Technische Daten

Ventil	2/2-, 3/2-Wege-Ventile
Medium	Druckluft
Prüfdruck	1.5MPa
Max. Betriebsdruck	1.0MPa
Betriebsvakuum*	-100kPa
Umgebungs- und Medientemperatur	0 bis 60°C
Verwendbares Schlauchmaterial (1)	Nylon, Weichnylon, PUR
Zubehör (Option)	Befestigungselement



Anm. 1) Achten Sie bei der Verwendung von Weichnylon- und PUR-Schläuchen auf den max. Betriebsdruck.
 * Verwenden Sie VHK2 (2-Wege-Ventil) für Vakuum-Anwendungen. VHK3 ist nicht für Vakuum-Anwendungen geeignet.



Symbol

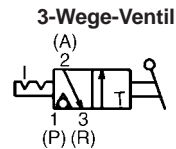
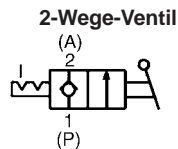

Konstruktion

2-Wege-Ventil/Serie VHK2

3-Wege-Ventil/Serie VHK3

Klare Erkennbarkeit des Schaltzustandes.
 (GESCHLOSSEN-OFFEN: Drehen gegen den Uhrzeigersinn)

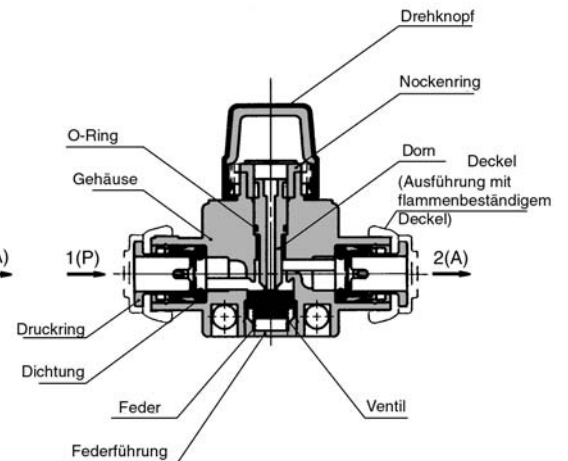
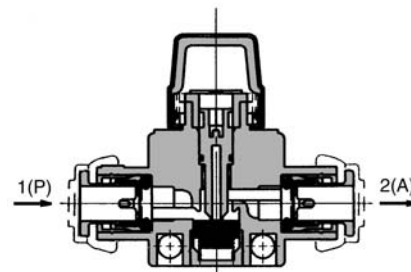
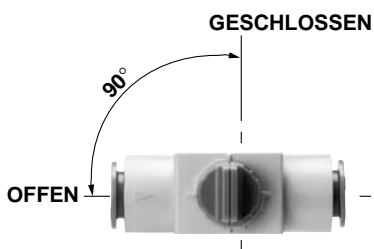

Anhand der Farbe des Drehknopfs kann leicht zwischen 2/2- und 3/2-Wege-Ventilen unterschieden werden.

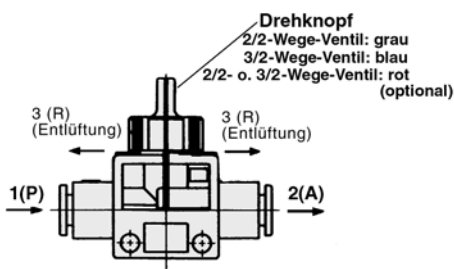

Stückliste

Gehäuse	Standardausführung	PBT
	Flammenbeständige Ausführung	Flammenbeständiges PBT (UL Standard V-0)
Drehknopf	Standardausführung	PBT
	Flammenbeständig Ausführung	Flammenbeständiges PBT (UL Standard V-0)
Deckel	Flammenbeständig (UL Standard V-0) CR Nur für Ausführung mit flammenbeständigem Deckel	
Nockenring	POM	
Dorn	POM	
Federführung	C3604B Chemisch vernickelt	
Feder	SUS304	
Dichtung, O-Ring, Ventil	NBR	

Bestellschlüssel

Standard

VHK 2 — 02S — 02S R L

Flammbeständig

VHK 2 R — 04F — 04F R L C

Ventilmodell

2	2/2-Wege-Ventil
3	3/2-Wege-Ventil

Flammbeständig

Grösse P-Anschluss

04F	ø4
06F	ø6
08F	ø8
10F	ø10
12F	ø12
M5	M5 X 0.8
01S	R(PT)1/8
02S	R(PT)1/4
03S	R(PT)3/8
04S	R(PT)1/2

Befestigungswinkel

—	ohne
L	mit L-Befestigungswinkel

*Der Befestigungswinkel und die Befestigungsschrauben sind montiert.

Flammbeständige Ummantelung

—	Ohne Ummantelung
C	Mit Ummantelung (Für Ausführung mit Steckverbindung)

Farbe Drehknopf

—	2/2-Wege-Ventil	Grau
(Standard)	3/2-Wege-Ventil	Blau
R (Option)	2/2-Wege-Ventil	Rot
	3/2-Wege-Ventil	

Grösse A-Anschluss

04F	ø4
06F	ø6
08F	ø8
10F	ø10
12F	ø12
M5	M5
01S	R(PT)1/8
02S	R(PT)1/4
03S	R(PT)3/8
04S	R(PT)1/2

S □ A

V □ A

S □ A

V □ A

VMVR

VH

Standard

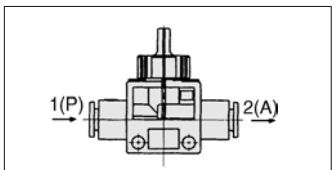

1(P): Steckverb./2(A): Steckverb.

		2(A) Verwendbarer Schlauch-Aussen-ø (mm)				
		ø4	ø6	ø8	ø10	ø12
Schlauch-Aussen-ø (mm)	ø4	●				
	ø6	●	●			
	ø8		●	●		
	ø10			●	●	
	ø12				●	●

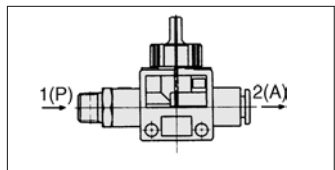

1(P): Aussengew./2(A): Steckverb.

		2(A) Verwendbarer Schlauch-Aussen-ø (mm)				
		ø4	ø6	ø8	ø10	ø12
Anschlussgrösse R(PT)	M5	●	●			
	1/8	●	●	●		
	1/4		●	●	●	●
	3/8		●	●	●	●
	1/2			●	●	●

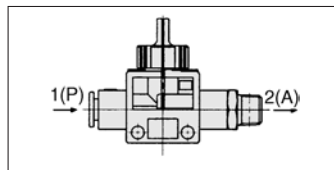

1(P): Steckverb./2(A): Aussengew.

		2(A) Anschlussgrösse R(PT)				
		M5	1/8	1/4	3/8	1/2
Schlauch-Aussen-ø (mm)	ø4	●	●			
	ø6	●	●	●	●	
	ø8		●	●	●	●
	ø10			●	●	●
	ø12			●	●	●

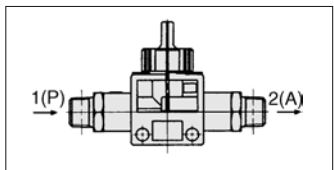

1(P): Aussengew./2(A): Aussengew.

		2(A) Anschlussgrösse R(PT)				
		M5	1/8	1/4	3/8	1/2
Anschlussgrösse R(PT)	M5	●				
	1/8	●	●			
	1/4		●	●		
	3/8			●	●	
	1/2				●	●

Flammenbeständige Ausführung (entspricht UL-94 Standard V-0)

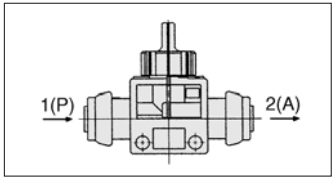

1(P): Steckverb./2(A):Steckverb.

		2(A) Verwendbarer Schlauch-Aussen-ø (mm)				
		ø4	ø6	ø8	ø10	ø12
Schlauch-Aussen-ø (mm)	ø4	●				
	ø6		●			
	ø8			●		
	ø10				●	
	ø12					●

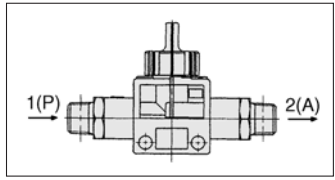

1(P): Aussengew./2(A): Aussengew.

		2(A) Anschlussgrösse R(PT)			
		1/8	1/4	3/8	1/2
Anschlussgrösse R(PT)	1/8	●			
	1/4		●		
	3/8			●	
	1/2				●

1(P)/2(A): Steckverbindung

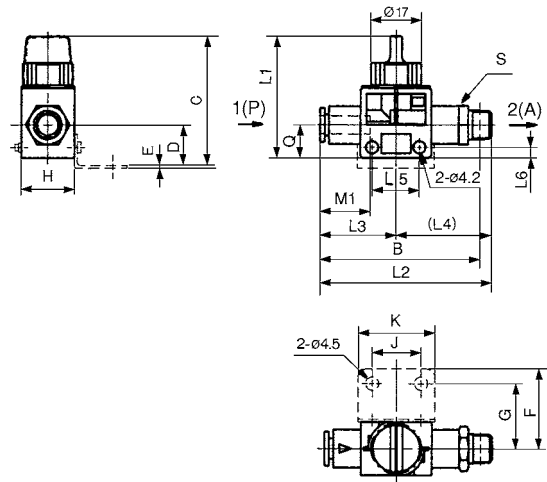

Schlauch Aussen-ø (mm)		Modell	H	L1	L2	L3	L4	L5	L6	M1	M2	Q	Äquivalenter Querschnitt (mm ²)		Gewicht (g)	Abmessungen Befestigungswinkel							
1(P)	2(A)												1(P)→2(A)	2(A)→3(R)*		Bestell-Nr. Befestigungswinkel	C	D	E	F	G	J	K
4	4	VHK□-04F-04F	18	41	47.6	23.8	23.8	16.5	3.5	15.8	15.8	11	3.4	1.2	15	VHK-B1A	44.5	14.5	1	27	22	16.5	26
6	4	VHK□-06F-04F	18	41	48	24.3	23.7	16.5	3.5	16.8	15.8	11	5.1	1.2	15	VHK-B1A	44.5	14.5	1	27	22	16.5	26
	6	VHK□-06F-06F			48.6		24.3						16.8		7.2								
8	6	VHK□-08F-06F	18	41	50.5	26.2	24.3	16.5	3.5	18.7	16.8	11	9	1.2	16	VHK-B1A	44.5	14.5	1	27	22	16.5	26
	8	VHK□-08F-08F			52.4		26.2						18.7		9.7								
10	8	VHK□-10F-08F	22	46	58.5	30.5	28	21.5	4	20.8	18.7	14	13.7	3.2	28	VHK-B2A	49	17	1	30	25	21.5	31
	10	VHK□-10F-10F			61		30.5						20.8		16.1								
12	10	VHK□-12F-10F	22	46	62	31.5	30.5	21.5	4	21.8	20.8	14	17	3.2	31	VHK-B2A	49	17	1	30	25	21.5	31
	12	VHK□-12F-12F			63		31.5						21.8		17.5								

1(P): Aussengewinde, 2(A): Steckverbindung

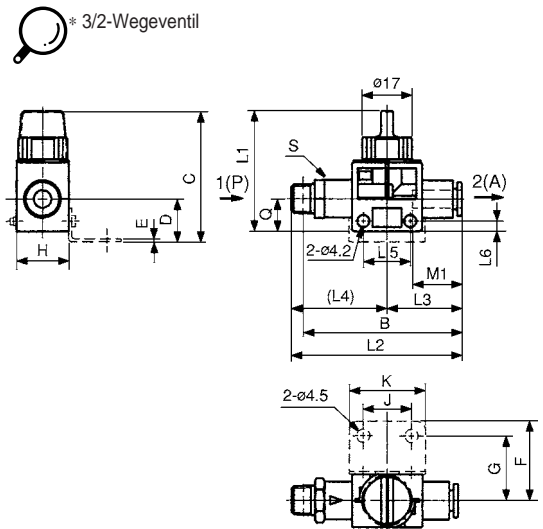
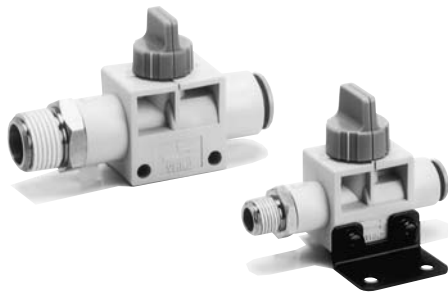

Anschluss-gewinde R(PT)	Schlauch Aussen-ø (mm)		Modell	H	L1	L2	L3	L4	L5	L6	M1	Q	Äquivalenter Querschnitt (mm ²)		Gewicht (g)	B**	S (Schlüsselweite)	Abmessungen Befestigungswinkel															
	1(P)	2(A)											1(P)→2(A)	2(A)→3(R)*				Bestell-Nr. Befestigungswinkel	C	D	E	F	G	J	K								
M5	4	VHK□-M5-04F	18	41	52.9	23.8	29.1	16.5	3.5	15.8	15.8	11	2.0	1.2	19	49	11	VHK-B1A	44.5	14.5	1	27	22	16.5	26								
	6	VHK□-M5-06F	53.9	24.3	29.6	16.8	21								50	13																	
1/8	4	VHK□-01S-04F	18	41	55.4	23.8	31.6	16.5	3.5	16.8	15.8	11	3.4	1.2	21	51	11	VHK-B1A	44.5	14.5	1	27	22	16.5	26								
	6	VHK□-01S-06F			56.9	24.3	32.6								16.8	23	53									13							
1/4	8	VHK□-01S-08F	18	41	62.2	26.2	36	16.5	3.5	18.7	16.8	11	7.2	1.2	31	58	17	VHK-B1A	44.5	14.5	1	27	22	16.5	26								
	6	VHK□-02S-06F			60.4	24.3	36.1								16.8	7.2	54									14							
	8	VHK□-02S-08F			65.2	26.2	39																				18.7	9.7	59	17			
	10	VHK□-02S-10F			73.8	30.5	43.3																								20.8	16.1	68
12	VHK□-02S-12F	76.3	31.5	44.8	21.8	17.5	70	22																									
3/8	6	VHK□-03S-06F	18	41					62.4	24.3	38.1	16.5	3.5	16.8	15.8	11	7.2	1.2	41	56	17	VHK-B1A	44.5	11.5	1	27							
	8	VHK□-03S-08F							66.2	26.2	40								18.7	40	60												
1/2	10	VHK□-03S-10F	22	46					74.8	30.5	44.3	21.5	4	20.8	16.1	14	16.1	3.2	51	68	19	VHK-B2A	49	17	1	30	25	21.5	31				
	12	VHK□-03S-12F			77.3	31.5	45.8	21.8	17.5	71	22																						
1/2	10	VHK□-04S-10F	22	46	78.2	30.5	47.7	21.5	4	20.8	16.1	14	16.1	3.2	72	70	22	VHK-B2A	49	17	1	30	25	21.5	31								
	12	VHK□-04S-12F			80.2	31.5	48.7								21.8	17.5	70									72							

1(P): Steckverbindung, 2(A): Aussengewinde

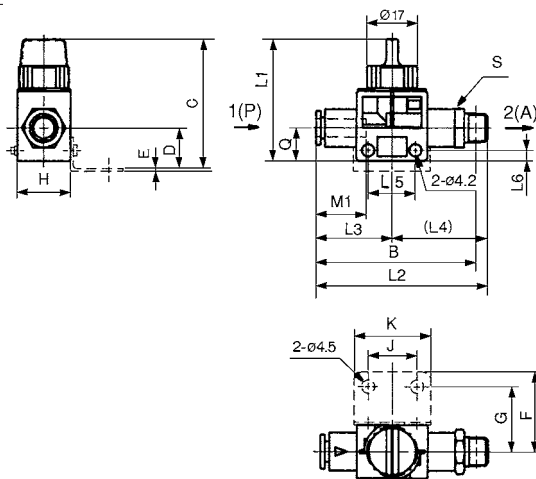

S□A
V□A

S□A
V□A

Schlauch Aussen-ø (mm)	Anschluss-gewinde R(PT)	Modell	H	L1	L2	L3	L4	L5	L6	M1	Q	Äquivalenter Querschnitt (mm ²)		Gewicht (g)	B**	S Schlüsselweite	Abmessungen Befestigungswinkel							
												1(P)→2(A)	2(A)→3(R)*				Bestell-Nr. Befestigungswinkel	C	D	E	F	G	J	K
4	M5	VHK□-04F-M5	18	41	52.9	23.8	29.1	16.5	3.5	15.8	11	2.0	1.2	19	49	11	VHK-B1A	44.5	14.5	1	27	22	16.5	26
	1/8	VHK□-04F-01S			55.4		31.6					3.4		21	51	13								
6	M5	VHK□-06F-M5	18	41	53.9	24.3	29.6	16.5	3.5	16.8	11	2.0	1.2	21	50	11	VHK-B1A	44.5	14.5	1	27	22	16.5	26
	1/8	VHK□-06F-01S			56.9		32.6							23	53	13								
	1/4	VHK□-06F-02S			60.4		36.1							31	54	17								
	3/8	VHK□-06F-03S			62.4		38.1							41	56	14								
8	1/8	VHK□-08F-01S	18	41	62.2	26.2	36	16.5	3.5	18.7	11	9.7	1.2	31	58	17	VHK-B1A	44.5	14.5	1	27	22	16.5	26
	1/4	VHK□-08F-02S			65.2		39							32	59	19								
	3/8	VHK□-08F-03S			66.2		40							40	60	22								
10	1/4	VHK□-10F-02S	22	46	73.8	30.5	43.3	21.5	4	20.8	14	16.1	3.2	49	68	17	VHK-B2A	49	17	1	30	25	21.5	31
	3/8	VHK□-10F-03S			74.8		44.3							51	70	19								
	1/2	VHK□-10F-04S			78.2		47.7							72	70	19								
12	1/4	VHK□-12F-02S	22	46	76.3	31.5	44.8	21.5	4	21.8	14	17.5	3.2	63	70	22	VHK-B2A	49	17	1	30	25	21.5	31
	3/8	VHK□-12F-03S			77.3		45.8							64	71	22								
	1/2	VHK□-12F-04S			80.2		48.7							70	72	22								

VM/VR
VH

* 3/2-Wegeventil
**Referenzabmessungen bei eingeschraubtem R(PT) Gewinde.

1(P)/2(A): Aussengewinde

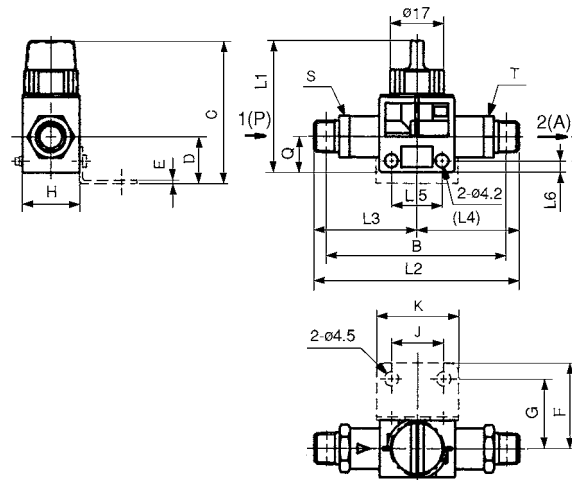
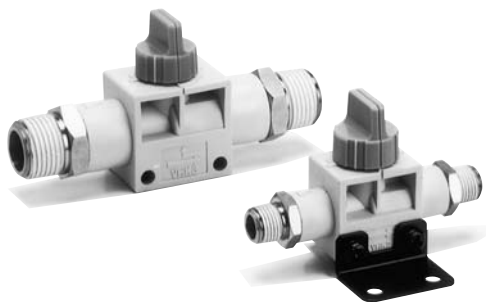

Anschluss-gewinde R(PT)		Modell	H	L1	L2	L3	L4	L5	L6	Q	Äquivalenter Querschnitt (mm ²)		Gewicht (g)	B**	S Schlüsselweite	T Schlüsselweite	Abmessungen Befestigungswinkel							
1(P)	2(A)										1(P)→2(A)	2(A)→3(R)*					Bestell-Nr. Befestigungswinkel	C	D	E	F	G	J	K
M5	M5	VHK□-M5-M5	18	41	58.2	29.1	29.1	16.5	3.5	11	2.0	1.2	23	51	11	11	VHK-B1A	44.5	14.5	1	27	22	16.5	26
1/8	M5	VHK□-01S-M5	18	41	61.6	32.6	29	16.5	3.5	11	2.0	1.2	26	54	13	13	VHK-B1A	44.5	14.5	1	27	22	16.5	26
	1/8	VHK□-01S-01S			65.2		32.6																	
1/4	1/8	VHK□-02S-01S	18	41	71.6	39	32.6	16.5	3.5	11	9.0	1.2	39	62	17	13	VHK-B1A	44.5	14.5	1	27	22	16.5	26
	1/4	VHK□-02S-02S			78		39																	
3/8	1/4	VHK□-03S-02S	22	46	85.1	44.3	40.8	21.5	4	14	13.7	3.2	65	73	19	17	VHK-B2A	49	17	1	30	25	21.5	31
	3/8	VHK□-03S-03S			88.6		44.3																	
1/2	3/8	VHK□-04S-03S	22	46	93	48.7	44.3	21.5	4	14	15.1	3.2	90	79	22	19	VHK-B2A	49	17	1	30	25	21.5	31
	1/2	VHK□-04S-04S			97.4		48.7																	

* 3/2-Wegeventil
**Referenzabmessungen bei eingeschraubtem R(PT) Gewinde.

⚠ Sicherheitshinweise

Vor der Inbetriebnahme durchlesen. Siehe S. 0-33 bis 0-36 für Sicherheitshinweise und allgemeine Vorsichtsmaßnahmen.

Konstruktion

⚠ Warnung

- Bei Verwendung eines anderen Mediums als Druckluft wenden Sie sich an SMC.
- Führen Sie nicht über den 2(A)-Anschluss Druckluft zu. Diese strömt ansonsten zum 1(P)-Anschluss.
- Da das Ventil eine geringe Leckage aufweist, ist es nicht zur Druckhaltung in Druckbehältern geeignet.

Auswahl

⚠ Achtung

Betriebsstellung:
Wenn der Drehknopf in einer Mittelstellung gehalten wird, können Fehlfunktionen auftreten. Drehen Sie ihn deshalb stets auf die EIN oder AUS-Position.

Montage

⚠ Achtung

Befestigung mittels L-Befestigungswinkel:
Ziehen Sie bei der Montage des Befestigungswinkels am Gehäuse die Schrauben mit einem Anzugsmoment von 0.5 bis 0.6 Nm an.

Flammbeständige Ausführung 1(P)/2(A): Steckverbindung

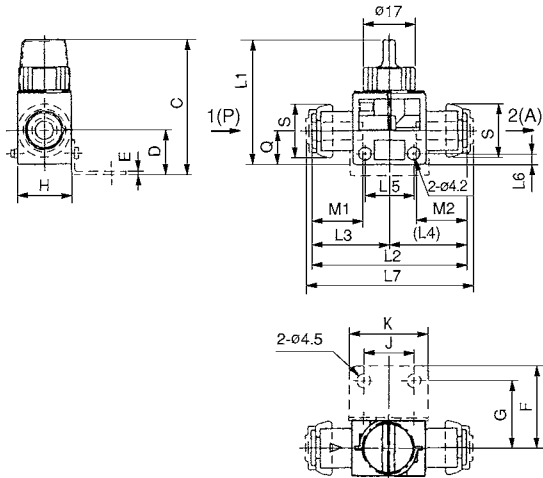

Schlauch-Aussen-ø (mm)	Modell	H	L1	L2	L3	L4	L5	L6	L7	Q	M1	M2	Äquivalenter Querschnitt (mm²)	
1(P) 2(A)													1(P)→2(A)	2(A)→3(R)
4 4	VHK□R-04F-04F	18	41	47.6	23.8	23.8	16.5	3.5	51.6	11	15.8	15.8	3.4	1.2
6 6	VHK□R-06F-06F	18	41	48.6	24.3	24.3	16.5	3.5	52.6	11	16.8	16.8	7.2	1.2
8 8	VHK□R-08F-08F	18	41	52.4	26.2	26.2	16.5	3.5	56.4	11	18.7	18.7	9.7	1.2
10 10	VHK□R-10F-10F	22	46	61	30.5	30.5	21.5	4	65	14	20.8	20.8	16.1	3.2
12 12	VHK□R-12F-12F	22	46	63	31.5	31.5	21.5	4	67	14	21.8	21.8	17.5	3.2

Schlauch-Aussen-ø (mm)	Modell	Gewicht (g)	S	Abmessungen Befestigungswinkel							
1(P) 2(A)				Bestell-Nr. Befestigungswinkel	C	D	E	F	G	J	K
4 4	VHK□R-04F-04F	15	ø14.4	VHK-B1A	44.5	14.5	1	27	22	16.5	26
6 6	VHK□R-06F-06F	16	ø16.8	VHK-B1A	44.5	14.5	1	27	22	16.5	26
8 8	VHK□R-08F-08F	17	ø19.2	VHK-B1A	44.5	14.5	1	27	22	16.5	26
10 10	VHK□R-10F-10F	29	ø23.3	VHK-B2A	49	17	1	30	25	21.5	31
12 12	VHK□R-12F-12F	32	ø25.7	VHK-B2A	49	17	1	30	25	21.5	31

Flammenbeständige Ausführung 1(P)/2(A): Aussengewinde

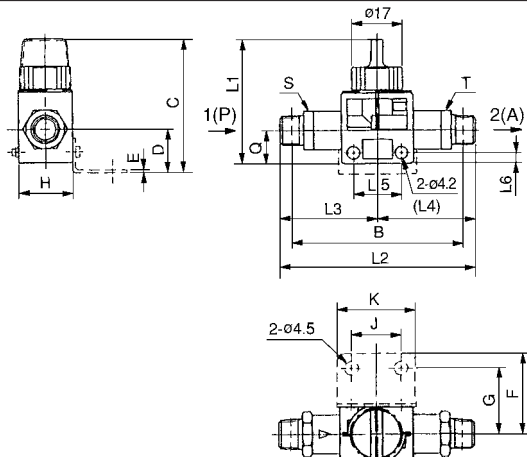

*Referenzabmessungen bei eingeschraubtem R(PT) Gewinde.

Anschluss-gewinde R(PT)	Modell	H	L1	L2	L3	L4	L5	L6	Q	B*	Äquivalenter Querschnitt (mm²)		Gewicht (g)
1(P) 2(A)											1(P)→2(A)	2(A)→3(R)	
1/8 1/8	VHK□R-01S-01S	18	41	65.2	32.6	32.6	16.5	3.5	11	57	8.6	1.2	30
1/4 1/4	VHK□R-02S-02S	18	41	78	39	39	16.5	3.5	11	66	9.7	1.2	47
3/8 3/8	VHK□R-03S-03S	22	46	88.6	44.3	44.3	21.5	4	14	76	16.1	3.2	72
1/2 1/2	VHK□R-04S-04S	22	46	97.4	48.7	48.7	21.5	4	14	81	17.5	3.2	101

Anschluss-gewinde R(PT)	Modell	S (Schlüsselweite)	T (Schlüsselweite)	Abmessungen Befestigungswinkel							
1(P) 2(A)				Bestell-Nr. Befestigungswinkel	C	D	E	F	G	J	K
1/8 1/8	VHK□R-01S-01S	13	13	VHK-B1A	44.5	14.5	1	27	22	16.5	26
1/4 1/4	VHK□R-02S-02S	17	17	VHK-B1A	44.5	14.5	1	27	22	16.5	26
3/8 3/8	VHK□R-03S-03S	19	19	VHK-B2A	49	17	1	30	25	21.5	31
1/2 1/2	VHK□R-04S-04S	22	22	VHK-B2A	49	17	1	30	25	21.5	31